

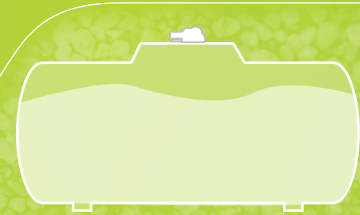

# Mopeka® Tank Sense

Underground and 420lb/120 gallon Vertical Tanks

ACCURACY  
ABOVE  
EVERYTHING



Mopeka® is the global leader in Sonar Tank Monitoring. We understand that Accurate, Reliable and Realtime Tank Monitoring is Critical. We believe in Accuracy Above Everything.

Imagine your Propane, Butane, Oil, Anhydrous, Water or any other liquid based business having an advantage above all others. You'll get that advantage with Mopeka's patented range of Sonar Tank Monitoring solutions. We harness the power of Sonar, Cloud and Mobile technologies to ensure you can quickly, easily and above all ACCURATELY monitor the levels of all your pressurized and non-pressurized tanks in Realtime, Anytime.

We provide solutions for both Pressurized and Non-pressurized Tanks, ranging from residential 20lb grills and RV tanks, right through to industrial tanks greater than 90,000 gallons. With over 95 years combined experience working with leading edge technology, engineering, and bulk commodities, we bring the best and the smartest solutions to life that help you better manage existing volumes and streamline supply chain management.

We provide a wide array of services:

- Sales of sonar tank monitoring solutions for a variety of products for example; Propane, Oil, Chemicals, Water, Beverages and more.
- A Suite of cloud-based software that allows you to manage and monitor tank levels from any internet connected device.
- Custom product design solutions that fit your needs and prices that are aggressively competitive.
- The latest in cloud-based software with our partner Amazon Web Services.

Customer Service is our top priority. With Mopeka® you get an organization focused on helping you improve and reach your long-term business goals. Contact us to learn more about how we can assist your firm with your mobile and remote tank monitoring needs.

## THE SOLUTION

Mopeka® offers a full line of tank monitoring sensors for both Pressurized and Non-pressurized Tanks. Whether you are looking to monitor your levels of Propane, Oil, Chemicals, Water and Beverages, or to ensure the protection of your underground tanks, we have the tank monitoring solution to meet your needs.

### Features of the Mopeka® Product Line:

- Our tank monitoring sensors work on a global SIM chip that operates on the 4G LTE CAT-M1, and NB-IoT networks.
- The sensors are so simple to install, there is no need for a technician.
- Mopeka® Tank Sense sensors are Class 1 Div 1, which means that since we don't penetrate the tank like traditional sensors, we are safer to operate in any environment.
- Mopeka® Tank Sense sensors will ensure a safe, consistent, accurate and reliable reading to ensure the protection of all your underground tanks.
- The average sensor's battery life is 5 years\*, so you don't need to worry about continually changing the battery and they're replaceable.

KEEP TRACK OF  
YOUR TANK LEVELS  
FROM ANYWHERE

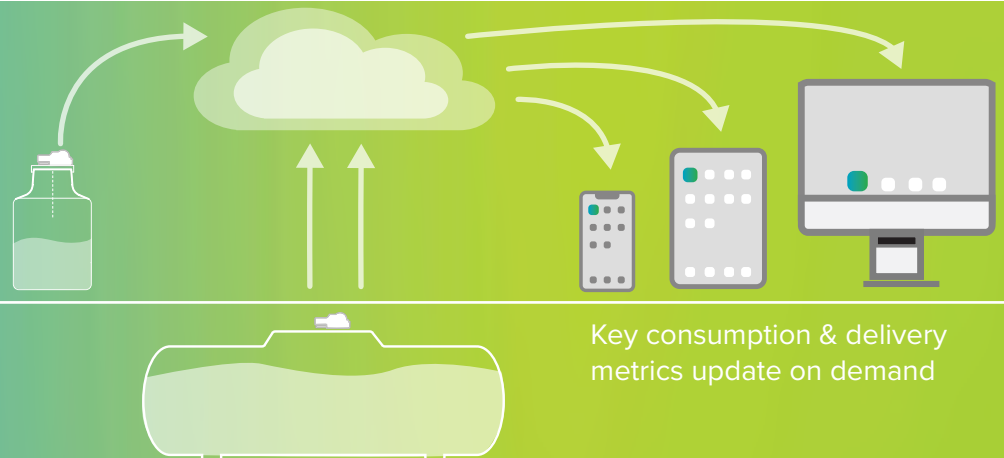

With Mopeka® you can monitor your tanks levels from your smartphone, tablet or computer.

Key consumption & delivery metrics update on demand

# Mopeka<sup>®</sup> Tank Sense

Tailored to seamlessly accommodate your 420 lb (120 gallon) vertical above-ground propane tanks, as well as underground tanks up to 2000 gallons. Experience unparalleled ease and convenience with our rapid, hassle-free monitoring solution. Trust in the unmatched accuracy provided by the trusted experts at Mopeka.<sup>®</sup>

Mopeka <sup>®</sup> Tank Sense	
<b>SENSOR</b>	Mopeka <sup>®</sup> Tank Sense
<b>COMMODITY</b>	Propane, Butane, Heating Oil, Diesel, Water, and other Liquids
<b>MOUNTING LOCATION</b>	Dial Attachment
<b>UL, UCL, ATEX CERTIFICATIONS</b>	Class 1, Division 1, Group D, Class 1, Zone 1, Group IIA IP68 and IK08
<b>TANK TYPE</b>	Vertical and Horizontal
<b>TANK ORIENTATION</b>	Above and Underground
<b>TANK SIZE</b>	420lb (120 gallon) - 2000 gallons**
<b>OPERATING TEMPERATURE RANGE</b>	-40C TO +70C -40F TO +158F
<b>DEFAULT COMMUNICATIONS</b>	Global SIM 4G LTE CAT M1, NB-IoT
<b>BATTERY LIFE*</b>	5 years, replaceable
<b>BATTERY TYPE</b>	Lithium Battery
<b>WARRANTY</b>	2 yrs

\*Based on 2 updates in a 24 hour period

\*\*Compatible with all the standard level gauge: Rochester (JR-SR - R3D)

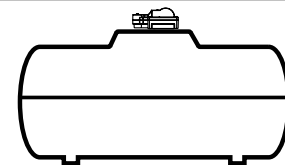
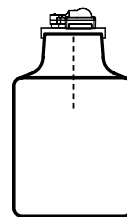
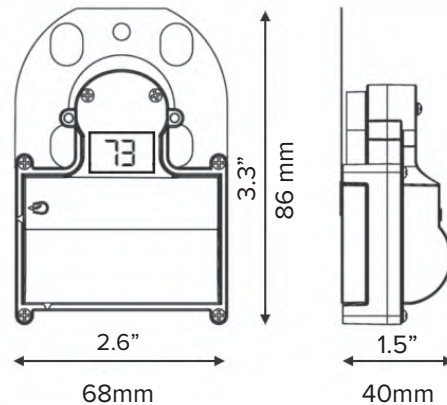

**MOPEKA PRODUCTS, LLC**

1223 Industrial Drive, Suite A  
New Braunfels, TX 78130

OFFICE: 833.667.3521